

Q-Gun™ Series

150 Amp MIG Guns

Issued Nov. 2006 • Index No. SPEC Q150-1.4

Q150 MIG Q-Gun™ shown with curved handle, medium 45° rotating neck.



Lightweight, comfortable and easy-to-use. Our Q150 MIG gun is a perfect fit for low amperage industrial applications.

All Guns are Not Created Equal.

A MIG gun should be durable, easy to use and customized to your specific application. Our MIG guns put you in control: you choose the options you need and we'll build a gun to last. We even ship most of our guns within 24 hours.

Centerfire™ contact tips, nozzles and diffusers are easy-to-use and high performing - they provide better arc starts, less spatter and more consistent welds - and also last up to three times longer than competitive brands.

Necks available in fixed, rotatable and multiple length options for optimal weld accessibility and improved operator comfort. Rotatable necks changeover without tools.

Patented Jump Liner allows quick neck change and replacement of only most commonly worn or clogged liner area, which reduces the amount of time a gun is offline and minimizes inventory.

Liners coiled in-house with proprietary process that improves wire feed performance and 100 percent tested to ensure smoothest wire feed in the industry.

Handle is comfortable to reduce user fatigue and ventilated to reduce heat.

Back end with durable rigid strain relief and easily interchangeable direct plugs and trigger leads connect to wire feeders and machines from major manufacturers and allow simple maintenance.

Q150 Amperage Ratings				Description
Duty Cycle				
100% NEMA	100%CE	60% CE	35%CE	
160	150	180	225	CO ₂ Gas
n/a	140	150	180	80%AR20%CO ₂

Made with
Pride and without
Compromise in the **USA**

Bernard®

An Illinois Tool Works Company
449 West Corning Road, Box 667
Beecher, Illinois 60401 USA

Phone: 800-946-2281 (US Only) 708-946-2281 (Outside US)
Fax: 708-946-6726
For more information, visit us at BernardWelds.com

BERNARD®

Replacement Parts List

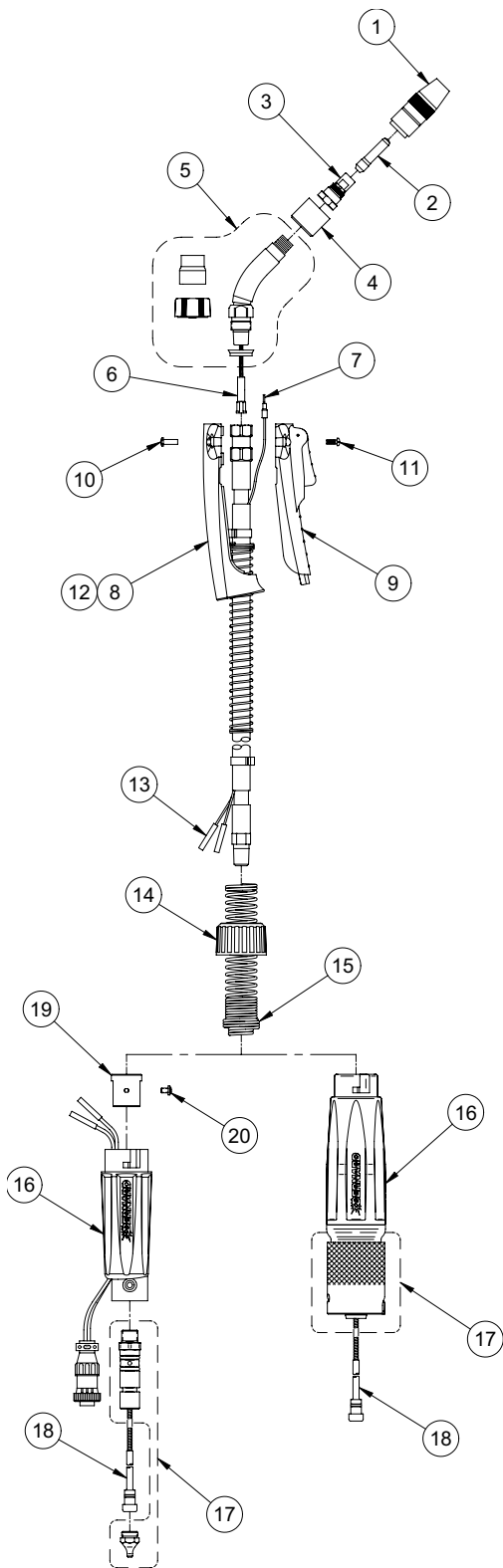

ITEM #	PART #	DESCRIPTION
1	See Centerfire Spec Sheet	Nozzle Assy
2	See Centerfire Spec Sheet	Contact Tip
3	See Centerfire Spec Sheet	Gas Diffuser
4	See Centerfire Spec Sheet	Cap
5	See Neck Spec Sheet	Neck
6	See Jump Liner Spec Sheet	Jump Liner
7	2660001	Terminal, Quick Disconnect (2 req'd)
8	1780062	Handle Half, Upper
9	2620054	Switch Assy, Handle Half, Lower
10	4207	Post Fastener (2 Req'd)
11	4209	Handle Screw (2 Req'd)
12	1880194	Handle Kit - (Includes: (1) #8, (1) #9, (2) #10, (2) #11)
13	4932	Butt Connector (2 Req'd)
14	2520007	Cap, Rigid Strain Relief
15	2520048	Spring, Strain Relief
16		Rigid Strain Relief
	2520073	Strain Relief with Installed Gas Pin (Bernard Direct Plug)
	2520047	Strain Relief (Euro Direct Plug)
	2520047E	Strain Relief with Trigger Cable Adapter (OXO, Tweco 4 w/Twist Lock)
	2520047H	Strain Relief with Trigger Cable Adapter (L-Tec, Hobart Direct Plug)
	2520047L	Strain Relief with Trigger Cable Adapter (Lincoln Direct Plug)
	2520047T	Strain Relief with Trigger Cable Adapter (National, Tweco Direct Plug)
	2520047M	Strain Relief with Trigger Cable Adapter (All Other Direct Plugs)
17	See Direct Plug Spec Sheet	Direct Plug Components
18	See Liner Spec Sheet	Liner
19	1010027	Adapter Block (Not Req'd on Bernard or Euro Direct Plug)
20	W11127-002	Screw, Strain Relief (Not Req'd on Bernard Direct Plug)